



# Low-Cost, SOT23, Voltage-Output, High-Side Current-Sense Amplifier

## General Description

The MAX4173 low-cost, precision, high-side current-sense amplifier is available in a tiny SOT23-6 package. It features a voltage output that eliminates the need for gain-setting resistors and it is ideal for today's notebook computers, cell phones, and other systems where current monitoring is critical. High-side current monitoring is especially useful in battery-powered systems, since it does not interfere with the ground path of the battery charger. The input common-mode range of 0 to +28V is independent of the supply voltage and ensures that the current-sense feedback remains viable even when connected to a battery in deep discharge. The MAX4173's wide 1.7MHz bandwidth makes it suitable for use inside battery charger control loops.

The combination of three gain versions and a user-selectable external sense resistor sets the full-scale current reading. This feature offers a high level of integration, resulting in a simple and compact current-sense solution.

The MAX4173 operates from a single +3V to +28V supply, typically draws only 420 $\mu$ A of supply current over the extended operating temperature range (-40°C to +85°C), and is offered in the space-saving SOT23-6 package.

## Applications

- Notebook Computers
- Portable/Battery-Powered Systems
- Smart Battery Packs/Chargers
- Cell Phones
- Power-Management Systems
- General System/Board-Level Current Monitoring
- PA Bias Control
- Precision Current Sources

## Features

- ◆ Low-Cost, Compact Current-Sense Solution
- ◆ Wide 0 to +28V Common-Mode Range Independent of Supply Voltage
- ◆ Three Gain Versions Available
  - +20V/V (MAX4173T)
  - +50V/V (MAX4173F)
  - +100V/V (MAX4173H)
- ◆  $\pm 0.5\%$  Full-Scale Accuracy
- ◆ 420 $\mu$ A Supply Current
- ◆ Wide 1.7MHz Bandwidth (MAX4173T)
- ◆ +3V to +28V Operating Supply
- ◆ Available in Space-Saving SOT23-6 Package

MAX4173T/F/H

## Typical Operating Circuit

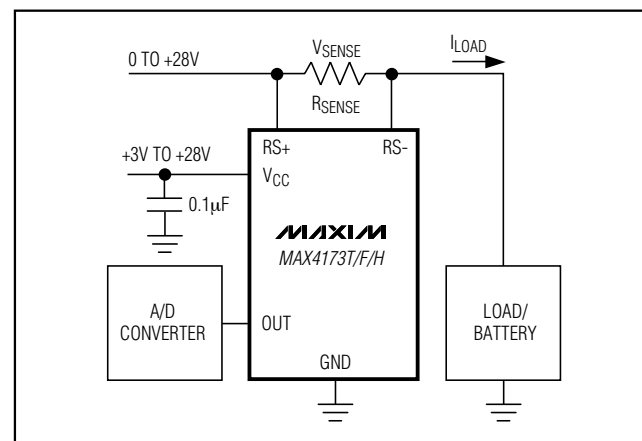

## Ordering Information

PART	GAIN (V/V)	TEMP. RANGE	PIN-PACKAGE	SOT TOP MARK
MAX4173TEUT-T	20	-40°C to +85°C	6 SOT23-6	AABN
MAX4173TESA	20	-40°C to +85°C	8 SO	-
MAX4173FEUT-T	50	-40°C to +85°C	6 SOT23-6	AABO
MAX4173FESA	50	-40°C to +85°C	8 SO	-
MAX4173HEUT-T	100	-40°C to +85°C	6 SOT23-6	AABP
MAX4173HESA	100	-40°C to +85°C	8 SO	-

Pin Configurations appear at end of data sheet.



# Low-Cost, SOT23, Voltage-Output, High-Side Current-Sense Amplifier

## ABSOLUTE MAXIMUM RATINGS

V<sub>CC</sub>, RS+, RS- to GND ..... -0.3V to +30V  
 OUT to GND ..... -0.3V to (V<sub>CC</sub> + 0.3V)  
 Output Short-Circuit to V<sub>CC</sub> or GND ..... Continuous  
 Differential Input Voltage (V<sub>RS+</sub> - V<sub>RS-</sub>) ..... ±0.3V  
 Current into Any Pin ..... ±20mA

Continuous Power Dissipation (T<sub>A</sub> = +70°C)  
 8-Pin SO (derate 5.88mW/°C above +70°C)..... 471mW  
 SOT23-6 (derate 8.7mW/°C above +70°C)..... 696mW  
 Operating Temperature Range ..... -40°C to +85°C  
 Storage Temperature Range ..... -65°C to +150°C  
 Lead Temperature (soldering, 10sec) ..... +300°C

Stresses beyond those listed under "Absolute Maximum Ratings" may cause permanent damage to the device. These are stress ratings only, and functional operation of the device at these or any other conditions beyond those indicated in the operational sections of the specifications is not implied. Exposure to absolute maximum rating conditions for extended periods may affect device reliability.

## ELECTRICAL CHARACTERISTICS

(V<sub>RS+</sub> = 0 to +28V, V<sub>CC</sub> = +3V to +28V, V<sub>SENSE</sub> = 0, T<sub>A</sub> = T<sub>MIN</sub> to T<sub>MAX</sub>, R<sub>LOAD</sub> = ∞ unless otherwise noted. Typical values are at T<sub>A</sub> = +25°C.) (Note 1)

PARAMETER	SYMBOL	CONDITIONS	MIN	TYP	MAX	UNITS
Operating Voltage Range	V <sub>CC</sub>	Guaranteed by PSR test	3		28	V
Common-Mode Input Range	V <sub>CMR</sub>	(Note 2)	0		28	V
Common-Mode Rejection	CMR	V <sub>RS+</sub> > +2.0V		90		dB
Supply Current	I <sub>CC</sub>	V <sub>RS+</sub> > +2.0V, V <sub>CC</sub> = 12V		0.42	1.0	mA
Leakage Current	I <sub>RS+</sub> , I <sub>RS-</sub>	V <sub>CC</sub> = 0		0.3	3	μA
Input Bias Current	I <sub>RS+</sub>	V <sub>RS+</sub> > +2.0V	0		50	μA
		V <sub>RS+</sub> ≤ +2.0V	-350		50	
	I <sub>RS-</sub>	V <sub>RS+</sub> > +2.0V	0		100	
		V <sub>RS+</sub> ≤ +2.0V	-700		100	
Full-Scale Sense Voltage	V <sub>SENSE</sub>	V <sub>SENSE</sub> = V <sub>RS+</sub> - V <sub>RS-</sub>		150		mV
Total OUT Voltage Error (Note 3)		V <sub>SENSE</sub> = +100mV, V <sub>CC</sub> = +12V, V <sub>RS+</sub> = +12V		±0.5	5.75	%
		V <sub>SENSE</sub> = +100mV, V <sub>CC</sub> = +12V, V <sub>RS+</sub> = +12V, T <sub>A</sub> = +25°C		0.5	3.25	
		V <sub>SENSE</sub> = +100mV, V <sub>CC</sub> = +28V, V <sub>RS+</sub> = +28V		0.5	5.75	
		V <sub>SENSE</sub> = +100mV, V <sub>CC</sub> = +12V, V <sub>RS+</sub> = +0.1V		-9	±24	
		V <sub>CC</sub> = +12V, V <sub>RS+</sub> = +12V, V <sub>SENSE</sub> = +6.25mV (Note 4)		±7.5		
OUT High Voltage (Note 5)	(V <sub>CC</sub> - V <sub>OH</sub> )	MAX4173T, V <sub>CC</sub> = +3.0V		0.8	1.2	V
		MAX4173F, V <sub>CC</sub> = +7.5V		0.8	1.2	
		MAX4173H, V <sub>CC</sub> = +15V		0.8	1.2	

# Low-Cost, SOT23, Voltage-Output, High-Side Current-Sense Amplifier

MAX4173T/F/H

## ELECTRICAL CHARACTERISTICS (continued)

(V<sub>RS+</sub> = 0 to +28V, V<sub>CC</sub> = +3V to +28V, V<sub>SENSE</sub> = 0, T<sub>A</sub> = T<sub>MIN</sub> to T<sub>MAX</sub>, R<sub>LOAD</sub> = ∞ unless otherwise noted. Typical values are at T<sub>A</sub> = +25°C.) (Note 1)

PARAMETER	SYMBOL	CONDITIONS		MIN	TYP	MAX	UNITS	
Bandwidth	BW	V <sub>RS+</sub> = +12V, V <sub>CC</sub> = +12V, C <sub>LOAD</sub> = 5pF	MAX4173T, V <sub>SENSE</sub> = +100mV,		1.7		MHz	
			MAX4173F, V <sub>SENSE</sub> = +100mV,		1.4			
			MAX4173H, V <sub>SENSE</sub> = +100mV,		1.2			
			V <sub>SENSE</sub> = +6.25mV, (Note 4)		0.6			
Gain	A <sub>V</sub>	MAX4173T			20		V/V	
		MAX4173F			50			
		MAX4173H			100			
Gain Accuracy	ΔA <sub>V</sub>	MAX4173T/F V <sub>SENSE</sub> = +10mV to +150mV	T <sub>A</sub> = -40°C to +85°C			4.0	%	
			T <sub>A</sub> = +25°C		0.5	±2.5		
		MAX4173H V <sub>SENSE</sub> = +10mV to +100mV	T <sub>A</sub> = -40°C to +85°C			4.0		
			T <sub>A</sub> = +25°C		0.5	±2.5		
OUT Settling Time to 1% of Final Value		V <sub>CC</sub> = +12V, V <sub>RS+</sub> = +12V, C <sub>LOAD</sub> = 5pF	V <sub>SENSE</sub> = +6.25mV to +100mV		400		ns	
			V <sub>SENSE</sub> = +100mV to +6.25mV		800			
OUT Output Resistance	R <sub>OUT</sub>				12		kΩ	
Power-Supply Rejection	PSR	MAX4173T, V <sub>SENSE</sub> = 80mV, V <sub>RS+</sub> ≥ +2V		60	84		dB	
		MAX4173F, V <sub>SENSE</sub> = 32mV, V <sub>RS+</sub> ≥ +2V		60	91			
		MAX4173H, V <sub>SENSE</sub> = 16mV, V <sub>RS+</sub> ≥ +2V		60	95			
Power-Up Time to 1% of Final Value		V <sub>SENSE</sub> = +100mV, C <sub>LOAD</sub> = 5pF			10		μs	
Saturation Recovery Time		V <sub>CC</sub> = +12V, V <sub>RS+</sub> = +12V (Note 6)			10		μs	

**Note 1:** All devices are 100% production tested at T<sub>A</sub> = +25°C. All temperature limits are guaranteed by design.

**Note 2:** Guaranteed by Total Output Voltage Error Test.

**Note 3:** Total OUT Voltage Error is the sum of gain and offset voltage errors.

**Note 4:** +6.25mV = 1/16 of +100mV full-scale voltage.

**Note 5:** V<sub>SENSE</sub> such that output stage is in saturation.

**Note 6:** The device does not experience phase reversal when overdriven.

# Low-Cost, SOT23, Voltage-Output, High-Side Current-Sense Amplifier

## Typical Operating Characteristics

( $V_{CC} = +12V$ ,  $V_{RS+} = +12V$ ,  $V_{SENSE} = +100mV$ ,  $T_A = +25^{\circ}C$ , unless otherwise noted.)

**SUPPLY CURRENT vs. SUPPLY VOLTAGE**

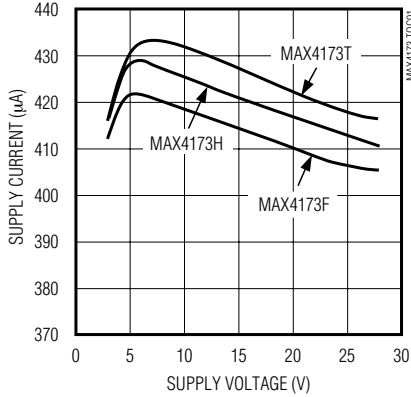

**SUPPLY CURRENT vs. TEMPERATURE**

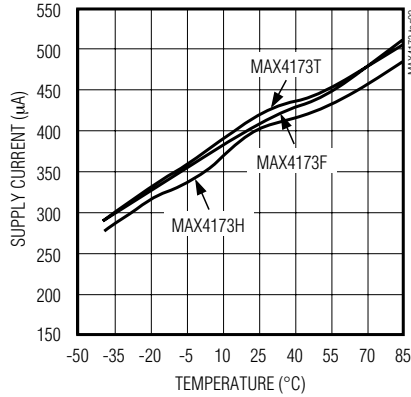

**SUPPLY CURRENT vs. RS+ VOLTAGE**

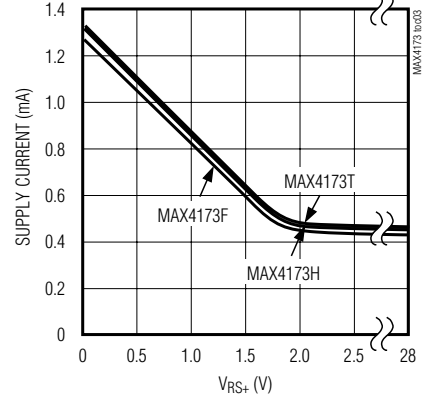

**TOTAL OUTPUT ERROR vs. SUPPLY VOLTAGE**

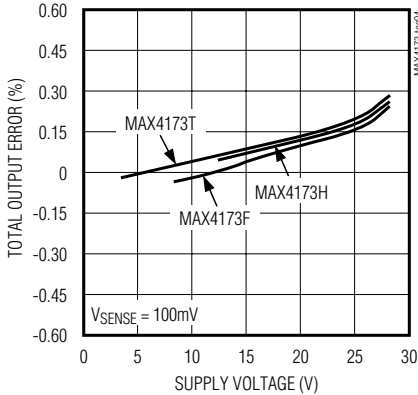

**TOTAL OUTPUT ERROR vs. SUPPLY VOLTAGE**

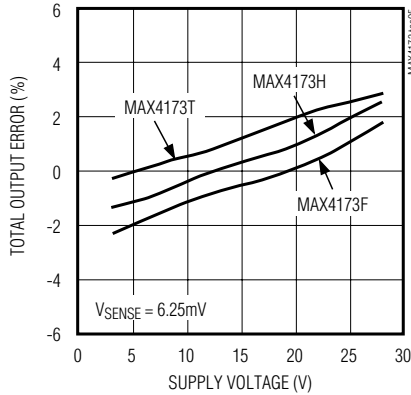

**TOTAL OUTPUT ERROR vs. FULL-SCALE SENSE VOLTAGE**

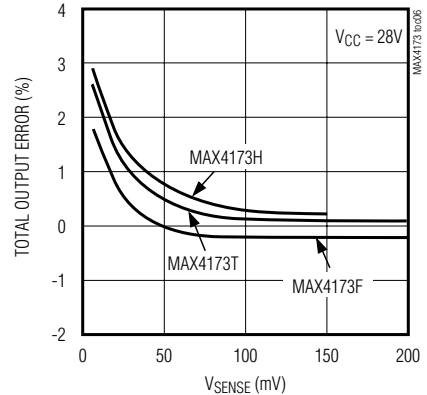

**POWER-SUPPLY REJECTION vs. FREQUENCY**

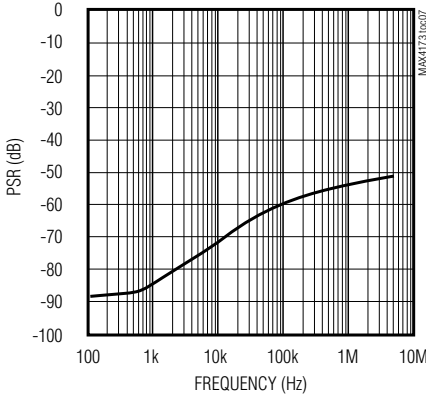

**TOTAL OUTPUT ERROR vs. COMMON-MODE VOLTAGE**

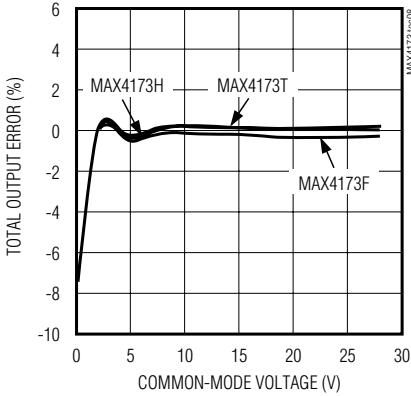

**GAIN ACCURACY vs. TEMPERATURE**

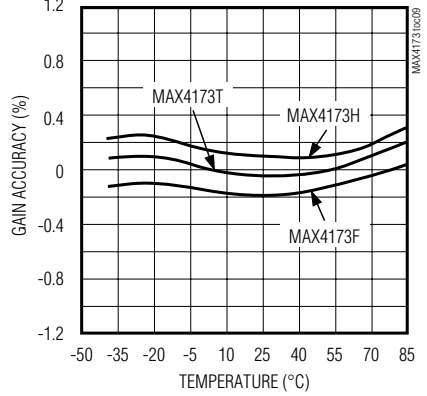

# Low-Cost, SOT23, Voltage-Output, High-Side Current-Sense Amplifier

MAX4173T/E/H

## Typical Operating Characteristics (continued)

( $V_{CC} = +12V$ ,  $V_{RS+} = +12V$ ,  $V_{SENSE} = +100mV$ ,  $T_A = +25^{\circ}C$ , unless otherwise noted.)

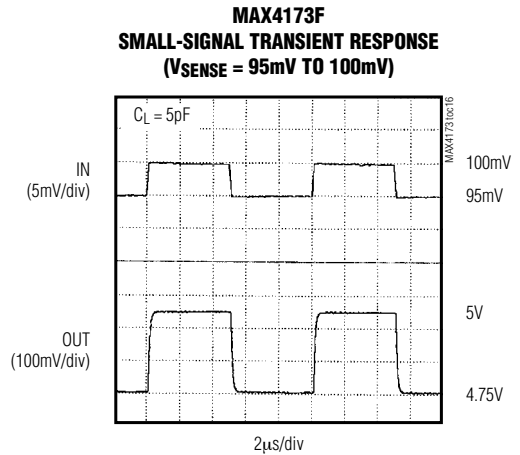
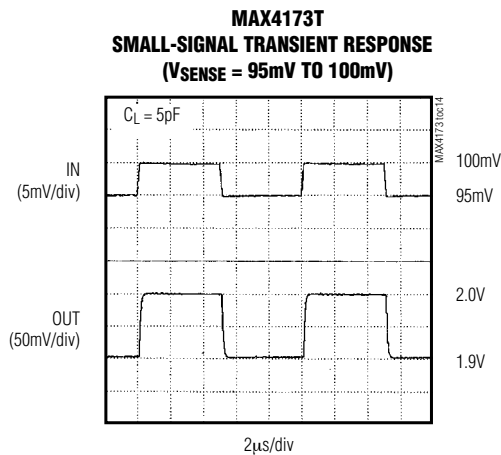
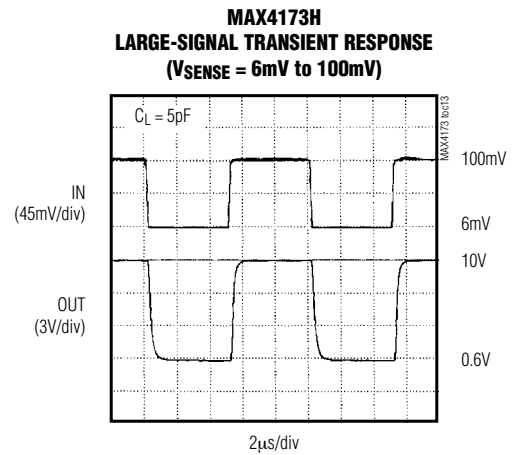
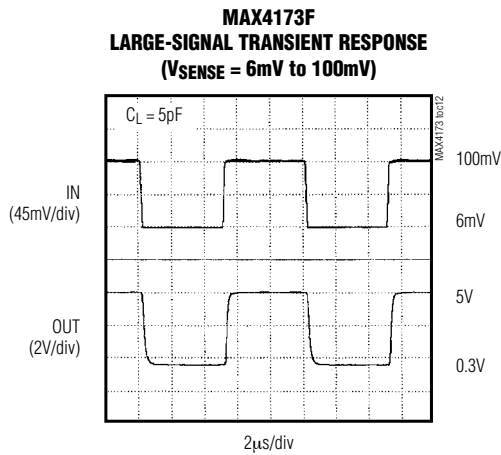
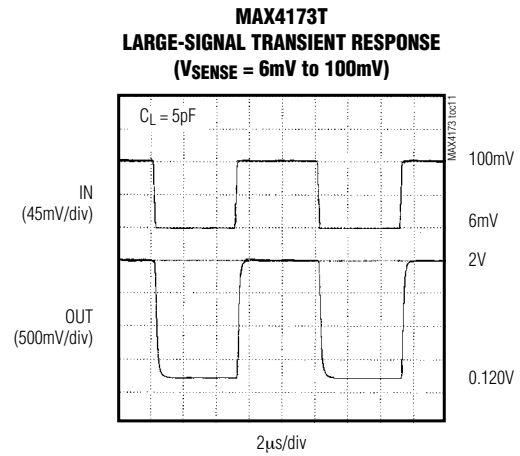
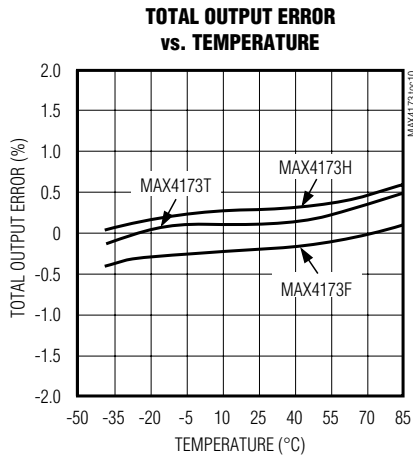

# Low-Cost, SOT23, Voltage-Output, High-Side Current-Sense Amplifier

## Typical Operating Characteristics (continued)

( $V_{CC} = +12V$ ,  $V_{RS+} = +12V$ ,  $V_{SENSE} = +100mV$ ,  $T_A = +25^{\circ}C$ , unless otherwise noted.)

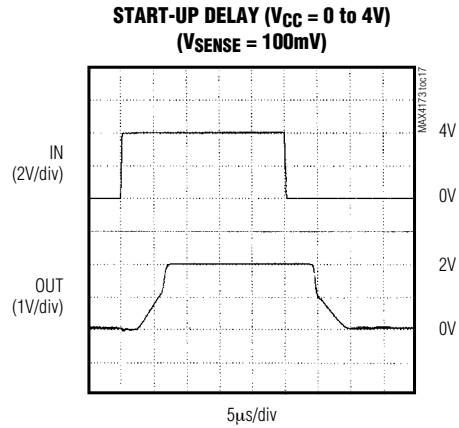
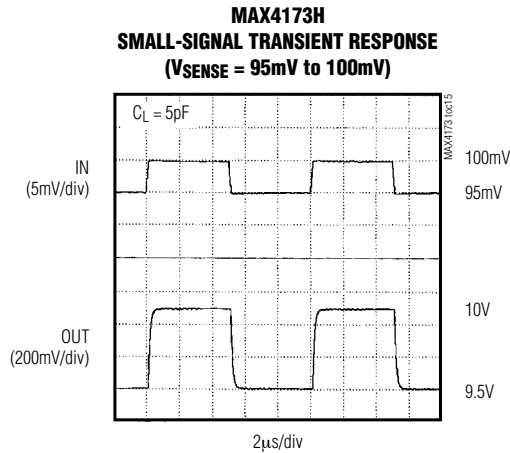

## Pin Description

PIN		NAME	FUNCTION
SOT23-6	SO		
1, 2	3	GND	Ground
3	1	V <sub>CC</sub>	Supply Voltage Input. Bypass to GND with a 0.1µF capacitor.
4	8	RS+	Power-Side Connection to the External Sense Resistor
5	6	RS-	Load-Side Connection for the External Sense Resistor
6	4	OUT	Voltage Output. $V_{OUT}$ is proportional to $V_{SENSE}$ ( $V_{RS+} - V_{RS-}$ ). Output impedance is approximately 12kΩ.
-	2, 5, 7	N.C.	No Connection. Not internally connected.

# Low-Cost, SOT23, Voltage-Output, High-Side Current-Sense Amplifier

MAX4173T/F/H

## Detailed Description

The MAX4173 high-side current-sense amplifier features a 0 to +28V input common-mode range that is independent of supply voltage. This feature allows the monitoring of current out of a battery in deep discharge and also enables high-side current sensing at voltages greater than the supply voltage ( $V_{CC}$ ).

The MAX4173 operates as follows: Current from the source flows through  $R_{SENSE}$  to the load (Figure 1). Since the internal-sense amplifier's inverting input has high impedance, negligible current flows through  $R_{G2}$  (neglecting the input bias current). Therefore, the sense amplifier's inverting-input voltage equals  $V_{SOURCE} - (I_{LOAD})(R_{SENSE})$ . The amplifier's open-loop gain forces its noninverting input to the same voltage as the inverting input. Therefore, the drop across  $R_{G1}$  equals  $(I_{LOAD})(R_{SENSE})$ . Since  $I_{RG1}$  flows through  $R_{G1}$ ,  $I_{RG1} = (I_{LOAD})(R_{SENSE}) / R_{G1}$ . The internal current mirror multiplies  $I_{RG1}$  by a current gain factor,  $\beta$ , to give  $I_{RGD} = \beta \cdot I_{RG1}$ . Solving  $I_{RGD} = \beta \cdot (I_{LOAD})(R_{SENSE}) / R_{G1}$ . Assuming infinite output impedance,  $V_{OUT} = (I_{RGD})(R_{GD})$ . Substituting in for  $I_{RGD}$  and rearranging,  $V_{OUT} = \beta \cdot (R_{GD} / R_{G1})(R_{SENSE} \cdot I_{LOAD})$ . The parts gain equals  $\beta \cdot R_{GD} / R_{G1}$ . Therefore,  $V_{OUT} = (GAIN)(R_{SENSE})(I_{LOAD})$ , where  $GAIN = 20$  for MAX4173T,  $GAIN = 50$  for MAX4173F, and  $GAIN = 100$  for MAX4173H.

Set the full-scale output range by selecting  $R_{SENSE}$  and the appropriate gain version of the MAX4173.

## Applications Information

### Recommended Component Values

The MAX4173 senses a wide variety of currents with different sense resistor values. Table 1 lists common resistor values for typical operation of the MAX4173.

### Choosing $R_{SENSE}$

To measure lower currents more accurately, use a high value for  $R_{SENSE}$ . The high value develops a higher sense voltage that reduces offset voltage errors of the internal op amp.

In applications monitoring very high currents,  $R_{SENSE}$  must be able to dissipate the  $I^2R$  losses. If the resistor's rated power dissipation is exceeded, its value may drift or it may fail altogether, causing a differential voltage across the terminals in excess of the absolute maximum ratings.

If  $I_{SENSE}$  has a large high-frequency component, minimize the inductance of  $R_{SENSE}$ . Wire-wound resistors have the highest inductance, metal-film resistors are somewhat better, and low-inductance metal-film resistors are best suited for these applications.

### Using a PCB Trace as $R_{SENSE}$

If the cost of  $R_{SENSE}$  is an issue and accuracy is not critical, use the alternative solution shown in Figure 2. This solution uses copper PCB traces to create a sense resistor. The resistivity of a 0.1-inch-wide trace of 2-ounce copper is approximately  $30\text{m}\Omega/\text{ft}$ . The resistance-temperature coefficient of copper is fairly high (approximately  $0.4\%/^{\circ}\text{C}$ ), so systems that experience a wide temperature variance must compensate for this effect. In addition, do not exceed the maximum power dissipation of the copper trace.

For example, the MAX4173T (with a maximum load current of 10A and an  $R_{SENSE}$  of  $5\text{m}\Omega$ ) creates a full-scale  $V_{SENSE}$  of 50mV that yields a maximum  $V_{OUT}$  of 1V.  $R_{SENSE}$  in this case requires about 2 inches of 0.1 inch-wide copper trace.

### Output Impedance

The output of the MAX4173 is a current source driving a  $12\text{k}\Omega$  resistance. Resistive loading added to OUT reduces the output gain of the MAX4173. To minimize output errors for most applications, connect OUT to a high-impedance input stage. When output buffering is required, choose an op amp with a common-mode input range and an output voltage swing that includes ground when operating with a single supply. The op

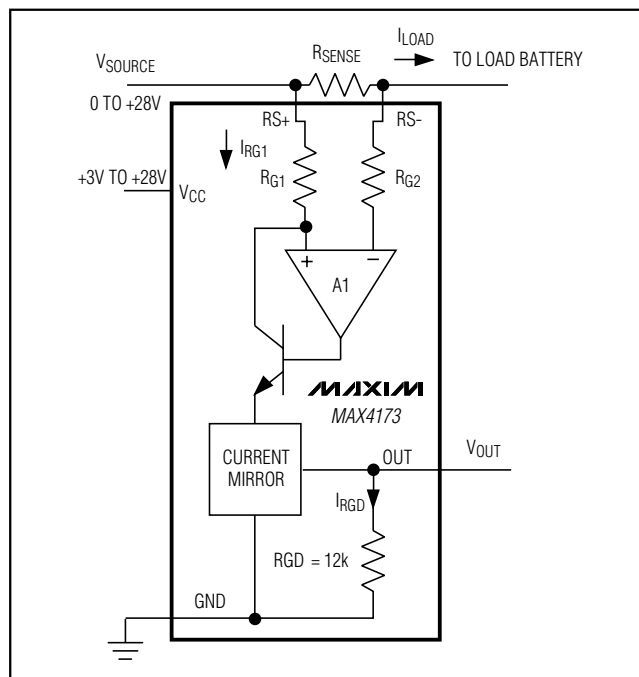

Figure 1. Functional Diagram

# Low-Cost, SOT23, Voltage-Output, High-Side Current-Sense Amplifier

Table 1. Recommended Component Values

FULL-SCALE LOAD CURRENT $I_{LOAD}$ (A)	CURRENT-SENSE RESISTOR $R_{SENSE}$ (m $\Omega$ )	GAIN	FULL-SCALE OUTPUT VOLTAGE (FULL-SCALE $V_{SENSE} = 100mV$ ) $V_{OUT}$ (V)
0.1	1000	20	2.0
		50	5.0
		100	10.0
1	100	20	2.0
		50	5.0
		100	10.0
5	20	20	2.0
		50	5.0
		100	10.0
10	10	20	2.0
		50	5.0
		100	10.0

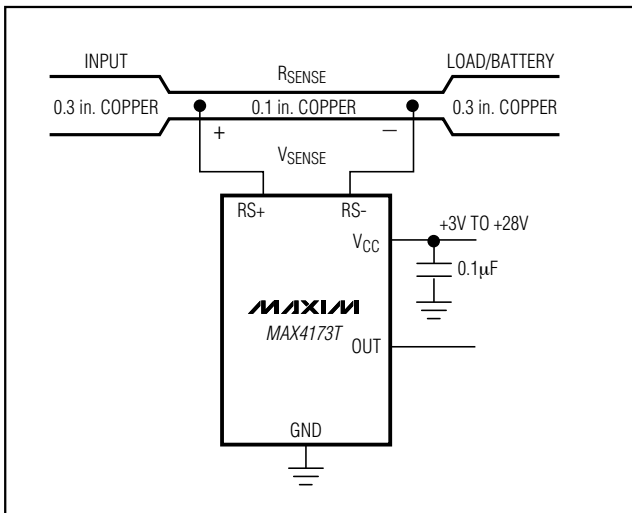

Figure 2. MAX4173 Connections Showing Use of PC Board

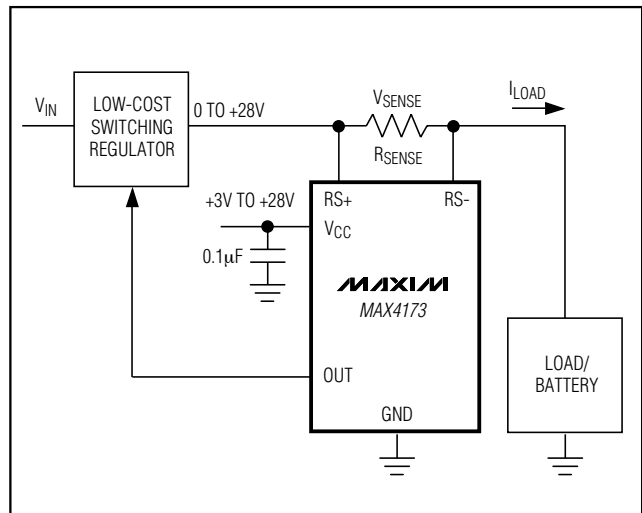

Figure 3. Current Source

amp's supply voltage range should be at least as high as any voltage the system may encounter.

The percent error introduced by output loading is determined with the following formula:

$$\%ERROR = 100 \left( \frac{R_{LOAD}}{12k\Omega + R_{LOAD}} - 1 \right)$$

where  $R_{LOAD}$  is the external load applied to OUT.

### Current Source Circuit

Figure 3 shows a block diagram using the MAX4173 with a switching regulator to make a current source.



# Low-Cost, SOT23, Voltage-Output, High-Side Current-Sense Amplifier

## Pin Configurations

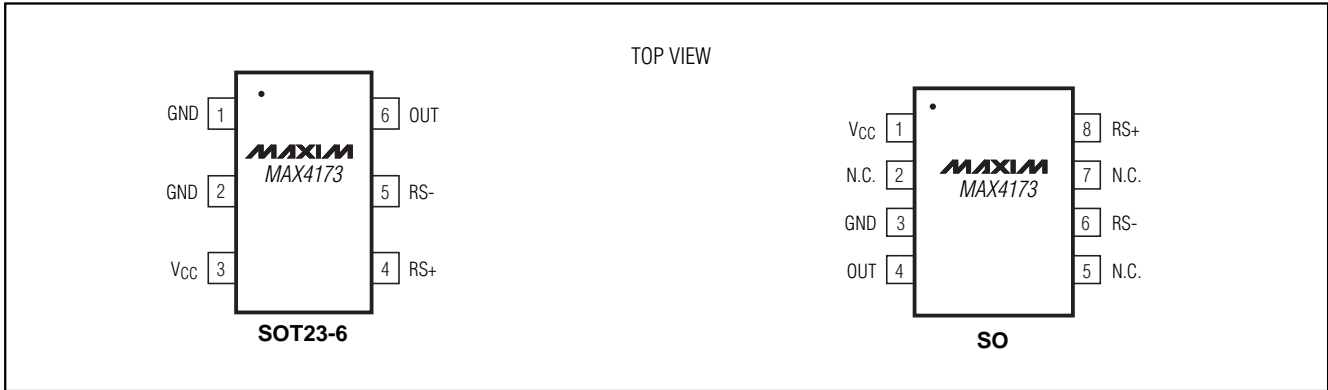

**MAX4173T/E/H**

## Chip Information

TRANSISTOR COUNT: 187

# Low-Cost, SOT23, Voltage-Output, High-Side Current-Sense Amplifier

## Package Information

(The package drawing(s) in this data sheet may not reflect the most current specifications. For the latest package outline information, go to [www.maxim-ic.com/packages](http://www.maxim-ic.com/packages).)

SYMBOL	MIN	MAX
A	0.90	1.45
A1	0.00	0.15
A2	0.90	1.30
b	0.35	0.50
C	0.08	0.20
D	2.80	3.00
E	2.60	3.00
E1	1.50	1.75
L	0.35	0.60
L1	0.60	REF.
e1	1.90	BSC.
e	0.95	BSC.
alpha	0°	10°

**NOTES:**

- ALL DIMENSIONS ARE IN MILLIMETERS.
- FOOT LENGTH MEASURED AT INTERCEPT POINT BETWEEN DATUM A & LEAD SURFACE.
- PACKAGE OUTLINE EXCLUSIVE OF MOLD FLASH & METAL BURR. MOLD FLASH, PROTRUSION OR METAL BURR SHOULD NOT EXCEED 0.25 MM.
- PACKAGE OUTLINE INCLUSIVE OF SOLDER PLATING.
- PIN 1 IS LOWER LEFT PIN WHEN READING TOP MARK FROM LEFT TO RIGHT. (SEE EXAMPLE TOP MARK)
- PIN 1 I.D. DOT IS 0.3 MM Ø MIN. LOCATED ABOVE PIN 1.
- MEETS JEDEC MO178, VARIATION AB.
- SOLDER THICKNESS MEASURED AT FLAT SECTION OF LEAD BETWEEN 0.08mm AND 0.15mm FROM LEAD TIP.
- LEAD TO BE COPLANAR WITHIN 0.1 MM.

**DALLAS SEMICONDUCTOR** **MAXIM**

PROPRIETARY INFORMATION

TITLE: PACKAGE OUTLINE, SOT-23, 6L

APPROVAL	DOCUMENT CONTROL NO. 21-0058	REV. F	1/1
----------	---------------------------------	-----------	-----

6LSOT23PS

# Low-Cost, SOT23, Voltage-Output, High-Side Current-Sense Amplifier

## Package Information (continued)

(The package drawing(s) in this data sheet may not reflect the most current specifications. For the latest package outline information, go to [www.maxim-ic.com/packages](http://www.maxim-ic.com/packages).)

MAX4173T/E/H

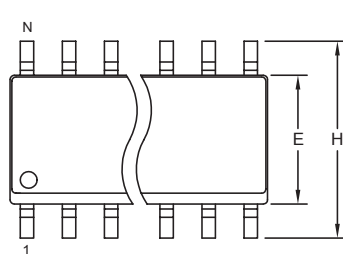

TOP VIEW

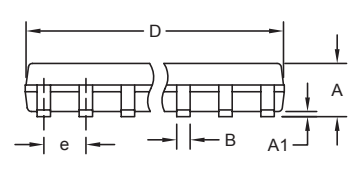

FRONT VIEW

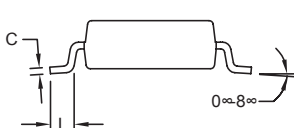

SIDE VIEW

**NOTES:**

1. D&E DO NOT INCLUDE MOLD FLASH.
2. MOLD FLASH OR PROTRUSIONS NOT TO EXCEED 0.15mm (.006").
3. LEADS TO BE COPLANAR WITHIN 0.10mm (.004").
4. CONTROLLING DIMENSION: MILLIMETERS.
5. MEETS JEDEC MS012.
6. N = NUMBER OF PINS.

DIM	INCHES		MILLIMETERS	
	MIN	MAX	MIN	MAX
A	0.053	0.069	1.35	1.75
A1	0.004	0.010	0.10	0.25
B	0.014	0.019	0.35	0.49
C	0.007	0.010	0.19	0.25
e	0.050 BSC		1.27 BSC	
E	0.150	0.157	3.80	4.00
H	0.228	0.244	5.80	6.20
L	0.016	0.050	0.40	1.27

VARIATIONS:

DIM	INCHES		MILLIMETERS		N	MS012
	MIN	MAX	MIN	MAX		
D	0.189	0.197	4.80	5.00	8	AA
D	0.337	0.344	8.55	8.75	14	AB
D	0.386	0.394	9.80	10.00	16	AC

SOICN LEPS

**DALLAS SEMICONDUCTOR** **MAXIM**

PROPRIETARY INFORMATION

TITLE: PACKAGE OUTLINE, .150" SOIC

APPROVAL	DOCUMENT CONTROL NO. 21-0041	REV. B	1/1
----------	---------------------------------	-----------	-----

Maxim cannot assume responsibility for use of any circuitry other than circuitry entirely embodied in a Maxim product. No circuit patent licenses are implied. Maxim reserves the right to change the circuitry and specifications without notice at any time.

Maxim Integrated Products, 120 San Gabriel Drive, Sunnyvale, CA 94086 408-737-7600 \_\_\_\_\_ 11